

HOURLASS WORM SLEW DRIVE
 125:1 GEARBOX REDUCTION RATIO
 150,000 ft. lb. MOMENT LOAD @ 5° SLOPE
 MODEL S21-125-24-R

TAPER BEARING AXIAL MOVEMENT
 GEAR BACKLASH
 RACEWAY TILT

NEW	REPLACE
.000-.003"	.010"
.021"	.039"
.007"	.035"

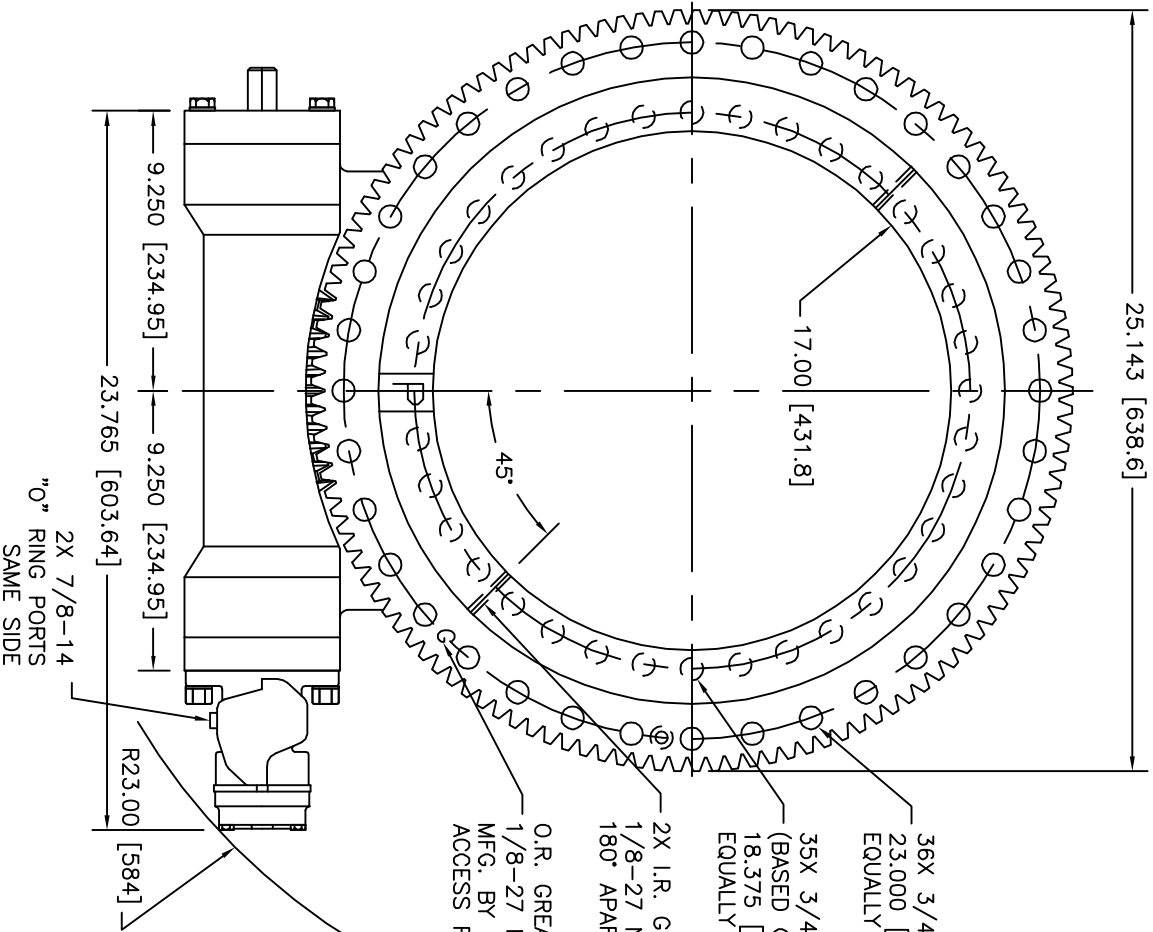
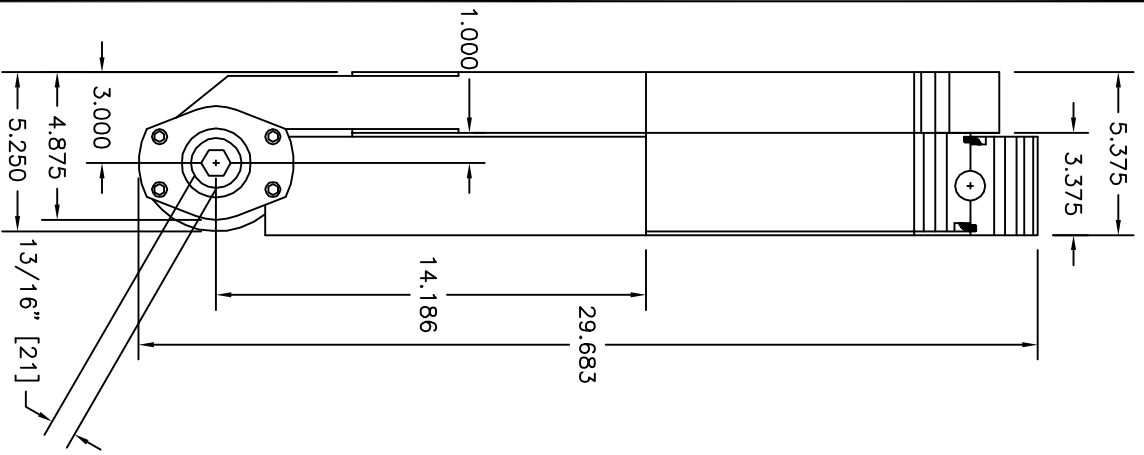

36X 3/4-10NC-2B THRU
 23.000 [584.2] B.C.
 EQUALLY SPACED

35X 3/4-10NC-2B THRU
 (BASED ON 36 HOLES, 1 OUT FOR PLUG)
 18.375 [466.7] B.C.
 EQUALLY SPACED

2X I.R. GREASE FITTING
 1/8-27 NPT
 180° APART

O.R. GREASE FIT
 1/8-27 NPT
 MFG. BY C'BORE BOTTOM AND TAP THRU
 ACCESS FROM TOP AND BOTTOM

2X 7/8-14
 "O" RING PORTS
 SAME SIDE

NOTES:
 AVAILABLE IN LEFT AND RIGHT HAND POSITIONS
 (MOTOR MOUNT SHOWN IN RIGHT HAND POSITION)

ALL PROPRIETARY RIGHTS IN THE SUBJECT MATTER HEREOF
 ARE RESERVED, AND NO PERMISSION IS GRANTED TO
 REPRODUCE OR TRANSMIT IN ANY FORM OR BY ANY
 MEANS, ELECTRONIC OR MECHANICAL, INCLUDING
 PHOTOCOPYING, RECORDING, OR BY ANY INFORMATION
 SYSTEMS, WITHOUT PERMISSION TO OTHERS.

MATERIAL	FINISH	WEIGHT	HEAT TREAT
UNSPECIFIED TOLERANCE LIMITS	UNSPECIFIED DIMENSIONAL TOL.	TITLE	
DD NOT SCALE	FRACTION X .001	21" BEARING	SLEWDRIVE™ www.SlewDrive.com HMEC (CHINA) CORP.
MACHINED FINISH 64 RMS MAX U.S.	DECIMAL ±.000 ±.005 ±.005		
CONCENTRICITY TLR			
ANGULAR DIMENSIONS ±	SCALE NTS	DRAWN BDB 08/25/06	SIZE A
REWORK ALL DIMS & SHARP EDGES SHARPEN MUST BE APPROVED BEFORE STANDARD PRODUCTION	PROJECT NO. SALES	CHECKED	DRAWING NUMBER H-S21B00
		APPROVED	REV B